

CITYBAC®

120L



SULO®

Citybac® 120L

PRODUCT DETAILS



- 1 Design Lid
- 2 3-sided all-round handle strip
- 3 Marking areas

- A Body
- B Handle bar
- C DIN comb lifting system, double stage
- D Marking areas
- E External wheels
- F Chip nest as standard
- G Lateral grip surfaces

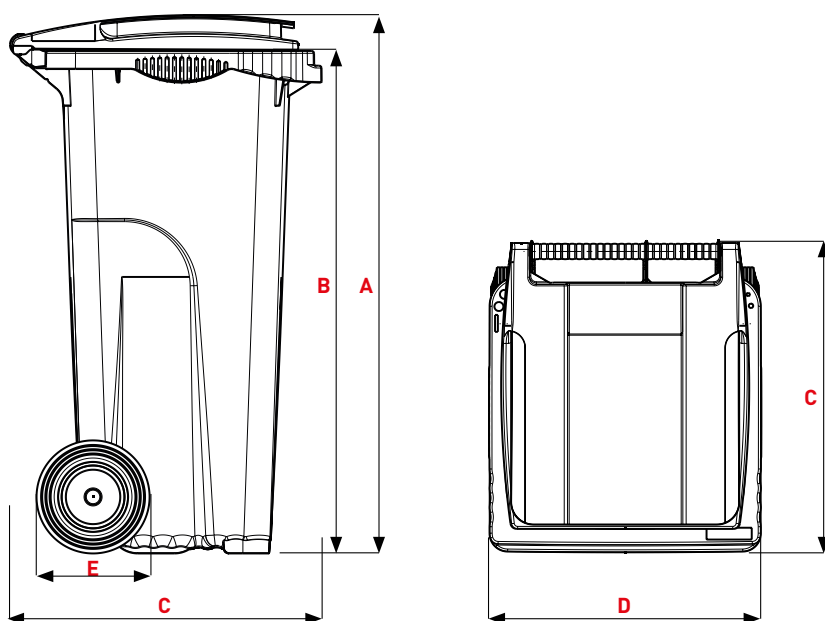

**DESIGN LID****Dimensions (mm)**

A Height total ~	940
B Comb height ~	889
C Bin depth ~	550
D Width total ~	480
E Wheel diameter ~	200

Weights

Nominal volume (L)	120
Empty weight (kg) ~	6,8
Max. filling weight (kg) ~ EN 840 Norm	48
Max. total weight (kg) ~	60

SILENT LID**Dimensions (mm)**

A Height total ~	950
B Comb height ~	889
C Bin depth ~	558
D Width total ~	480
E Wheel diameter ~	200

Weights

Nominal volume (L)	120
Empty weight (kg) ~	7,2
Max. filling weight (kg) ~ EN 840 Norm	48
Max. total weight (kg) ~	60

Citybac® 120L

PRODUCT DETAILS

COLOURING



ANTHRACITE GREY
RAL 7021
AT

CIRCULAR ECO 

Bin bodies made of up to 100 % post-consumption recycle. We are able to achieve an average share of 70 % domestic recycle (packaging, caps) and 30 % nondomestic (bins, industrial scrap, pallets)

100% RECYCLED MATERIAL



RAL 7021



RAL 7011



RAL 6011



RAL 6009



RAL 8025



RAL 5023

VIRGIN MATERIAL



RAL 9010



RAL 7038



RAL 5015



RAL 5005



PANTONE 5395C



RAL 3974GN



PANTONE 167 C



RAL 3000



RAL 3005



RAL 1018

ALTERNATIVE COLOURS FOR THE BIN BODY



GREEN
RAL
6011
VJ

CIRCULAR ECO 



BROWN
RAL
8025
MR

CIRCULAR ECO 



BLUE
RAL
5023
BN

CIRCULAR ECO 



RED
RAL
3000
RN

CIRCULAR ECO 



ORANGE
PANTONE
167 C
OF

CIRCULAR ECO 



YELLOW
RAL
1018
JA

CIRCULAR ECO 

Other colours and colour combinations available on request, subject to sufficient order quantities. Colours may vary due to production. The colour values given according to RAL are guide colours.

+ OPTIONS

FRACTION MARKING



Clip available in the colours



Label for Silent and Design Lid, individual printing possible

LID SLOT SYSTEMS

Packaging



Lid-in-Lid, small Lid always in **Yellow RAL 1018**

Glass



Round slot with rubber rosette Ø 150 mm, lock or bolt required

Paper



Paper hood for newspapers and magazines in **Blue RAL 5023**



Slot for confidential paper

NOISE REDUCTION



Plastic damper spring for the wheels

ACCESSORIES



Fixed position



Lid opening via pedal

WHEELS



Lightweight, recycled and recyclable Ø 200 mm wheels



Solid rubber Ø 200 mm wheels

LOCKING SYSTEMS



Automatic lock with triangular key



Automatic lock with individual key



Automatic bolt



Manual lock with individual key



Manual lock with triangular key

Citybac® 2-Wheel

TECHNICAL INFORMATION

120 LITRE

LIFTING SYSTEM	
DIN COMB	■
LID TYPE	
Standard	
Silent	■
Design	■
Butterfly horizontal	
LID SLOT SYSTEMS	
Paper	Design
Slot for confidential paper	Design
Glass	Design
Packaging	Design
Household waste	Design Silent
Clips	■
NOISE REDUCTION	
Plastic damper	■
LOCKING SYSTEMS	
Manual lock	Design
Automatic lock	Design
Automatic bolt	Design
Padlock device	■
DIVIDER WALL	
Vertical 40/60	
Vertical 50/50	
Vertical 60/40	
Horizontal 40/60	
Horizontal 60/40	

120 LITRE

HANDLES (NOT AVAILABLE ON MST5)	
Side handle	■
WHEELS DIAMETER (HOLLOW OR SOLID AXLE)	
ø 200 mm	■
ø 250 mm	
ø 300 mm	
ACCESSOIRES	
Lid opening via pedal	Silent
Poste fixe	Design Silent
ANTI-ODOUR	
Anti-odour	■
LABELLING	
Photo injection on the lid	Design Silent
Sticker	■
Embossing insert on the lid	■
Hot foil stamping	■
IDENTIFICATION	
RFID Chip	■
Specific numbering	■

sulo.com

DATA-CITYBAC-120L-LA-EN-1-0-201221

SULO[®]