

CITYBAC®

80L



SULO®

Citybac® 80L

PRODUKTDDETAILS



- 1 Standard Deckel
- 2 Griffe 2x
- 3 Deckelniet 2x
- 4 Kennzeichnungsflächen

- A Rumpf
- B durchgehendes Griffrohr
- C DIN-Kammaufnahme, doppelstufig
- D Kennzeichnungsfläche
- E außen liegende Räder
- F Chipnest serienmäßig



MANUAL LOCK

AUTOMATIC LOCK

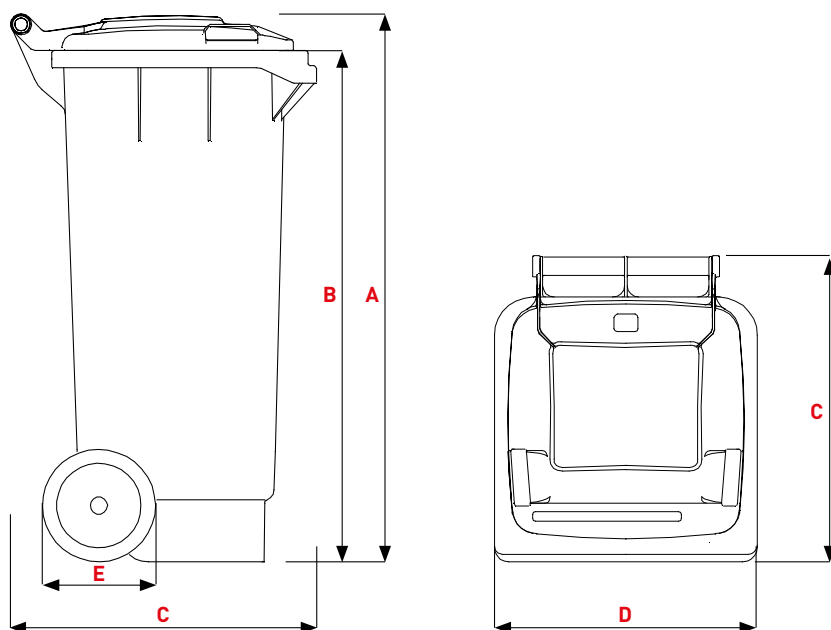

STANDARD DECKEL

Dimensionen (mm)

A Höhe gesamt ~	940
B Oberkante Kammaufnahme ~	880
C Tiefe des Behälters ~	525
D Breite gesamt ~	450
E Durchmesser Rad ~	200

Gewichte

Nennvolumen (L)	80
Leergewicht (kg) ~	8,7
max. Füllgewicht (kg) ~ EN 840 Norm	32
Zul. Gesamtgewicht (kg) ~	50

Maße können produktionsbedingt abweichen. Bei den Leergewichten handelt es sich um einen gerundeten Durchschnittswert basierend auf der Standard-Ausführung. Die tatsächlichen Gewichte können produktions- und spezifikationsbedingt abweichen.

Citybac® 80L

PRODUKTDDETAILS

FARBGEBUNG



GRAU
RAL 7021
AT
CIRCULAR ECO



Behälterrumpfe aus 100 % recyceltem Material mit einem Anteil von mindestens 70 % an Post-Consumer-Recyclingmaterial

100% RECYCLTES MATERIAL



RAL 7021



RAL 7011



RAL 6011



RAL 6009



RAL 8025



RAL 5023

NEUWARE



RAL 9010



RAL 7038



RAL 5015



RAL 5005



PANTONE 5395C



RAL 3974GN



PANTONE 167 C



RAL 3000



RAL 3005



RAL 1018

ALTERNATIVE FARBEN FÜR DEN BEHÄLTERRUMPF



GRÜN
RAL
6011
VJ

CIRCULAR ECO



BRAUN
RAL
8025
MR

CIRCULAR ECO



BLAU
RAL
5023
BN

CIRCULAR ECO



ROT
RAL
3000
RN

CIRCULAR ECO



ORANGE
PANTONE
167 C
OF

CIRCULAR ECO



GELB
RAL
1018
JA

CIRCULAR ECO



+ OPTIONEN

EINWURFSYSTEME

Glas



150 mm mit Blendring und Gummiring und Gummirosette, Schloss oder Verschluss erforderlich

GERÄUSCHDÄMPFUNG



Kunststofffeder für die Räder

ZUBEHÖR



Standplatzfixierung

RÄDER



Leicht, recycelt und wiederverwertbar
Ø 200 mm Rad



Ø 200 mm Rad



Ø 250 mm Rad

SCHLÖSSER



Dreikantschloss mit Automatikfunktion



Zylinderschloss mit Automatikfunktion



Zylinderschloss ohne Automatikfunktion



Dreikantschloss ohne Automatikfunktion

Citybac® 2Rad

TECHNISCHE INFORMATIONEN

80 LITER

AUFNAHMESYSTEM

EN 840 / DIN Kammaufnahme

■

DECKELSYSTEME

Standard

■

EINWURFSYSTEME

Glas

Standard

Restmüll

Standard

GERÄUSCHDÄMPFUNG

Kunststoffdämpfer

■

SCHLOSSSYSTEME

ohne Automatikfunktion

Standard

mit Automatikfunktion

Standard

80 LITER**GRIFFE (NICHT VERFÜGBAR AUF MST5)**

Seitliche Griffe	■
------------------	---

RÄDER

ø 200 mm	■
----------	---

ø 250 mm	■
----------	---

ø 300 mm	
----------	--

ZUBEHÖR

Deckelöffnung mit Pedal	
-------------------------	--

Standplatzfixierung	Standard
---------------------	----------

ANTIGERUCH

Antigeruch	■
------------	---

KENNZEICHNUNG

Fotoinjection auf dem Deckel	Standard
------------------------------	----------

Aufkleber	■
-----------	---

Deckelprägeeinsatz	■
--------------------	---

Heißprägung	■
-------------	---

IDENTIFIKATION

RFID Chip	■
-----------	---

Laufende Nummern	■
------------------	---

sulo.de

DATA-CITYBAC-80L-LA-DE-1-0-240122

SULO®