

CITYBAC®

80L



SULO®

Citybac® 80L

PRODUCT DETAILS



- 1 Standard Lid
- 2 Handles 2x
- 3 Lid rivet 2x
- 4 Marking areas

- A Body
- B Continuous handle bar
- C DIN comb lifting system, double stage
- D Marking areas
- E External wheels
- F Chip nest as standard



MANUAL LOCK

AUTOMATIC LOCK

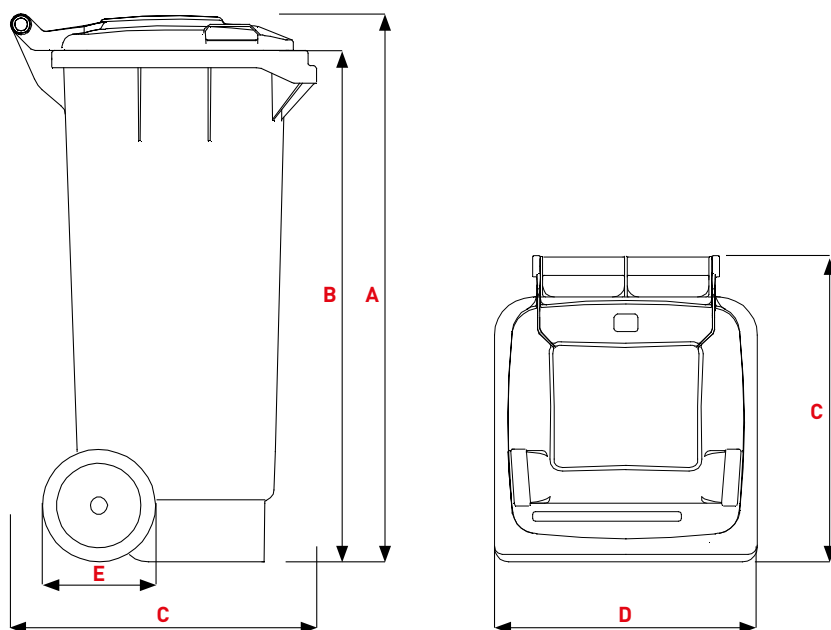

STANDARD LID

Dimensions (mm)

A Height total ~	940
B Comb height ~	880
C Bin depth ~	525
D Width total ~	450
E Wheel diameter ~	200

Weights

Nominal volume (L)	80
Empty weight (kg) ~	8,7
Max. filling weight (kg) ~ EN 840 Norm	32
Max. total weight (kg) ~	50

Dimensions may vary due to production conditions. The specified empty weights are rounded average based on the standard specifications. The actual weight may be different as a result of production conditions and specifications.

Citybac® 80L

PRODUCT DETAILS

COLOURING



ANTHRACITE GREY
RAL 7021
AT

CIRCULAR ECO
■■■■■

Bin bodies made of up to 100 % post-consumption recycle. We are able to achieve an average share of 70 % domestic recycle (packaging, caps) and 30 % nondomestic (bins, industrial scrap, pallets)

100% RECYCLED MATERIAL



RAL 7021



RAL 7011



RAL 6011



RAL 6009



RAL 8025



RAL 5023

VIRGIN MATERIAL



RAL 9010



RAL 7038



RAL 5015



RAL 5005



PANTONE 5395C



RAL 3974GN



PANTONE 167 C



RAL 3000



RAL 3005



RAL 1018

ALTERNATIVE COLOURS FOR THE BIN BODY



GREEN
RAL
6011
VJ

CIRCULAR ECO
■■■■■



BROWN
RAL
8025
MR

CIRCULAR ECO
■■■■■



BLUE
RAL
5023
BN

CIRCULAR ECO
■■■■■



RED
RAL
3000
RN

CIRCULAR ECO
■■■■■



ORANGE
PANTONE
167 C
OF

CIRCULAR ECO
■■■■■



YELLOW
RAL
1018
JA

CIRCULAR ECO
■■■■■

Other colours and colour combinations available on request, subject to sufficient order quantities. Colours may vary due to production. The colour values given according to RAL are guide colours.

+ OPTIONS

LID SLOT SYSTEMS

Glass



Round slot with rubber rosette
Ø 150 mm, lock or bolt required

NOISE REDUCTION



Plastic damper spring for the wheels

ACCESSORIES



Fixed position

WHEELS



Lightweight, recycled and recyclable
Ø 200 mm wheels



Solid rubber
Ø 200 mm wheels



Solid rubber
Ø 250 mm wheels

LOCKING SYSTEMS



Automatic lock with triangular key



Automatic lock with individual key



Manual lock with individual key



Manual lock with triangular key

Citybac® 2-Wheel

TECHNICAL INFORMATION

80 LITRE

LIFTING SYSTEM	
DIN COMB	■
LID TYPE	
Standard	■
Silent	
Design	
Butterfly horizontal	
LID SLOT SYSTEMS	
Paper	
Slot for confidential paper	
Glass	Standard
Packaging	
Household waste	Standard
Clips	
NOISE REDUCTION	
Plastic damper	■
LOCKING SYSTEMS	
Manual lock	Standard
Automatic lock	Standard
Automatic bolt	
Padlock device	
DIVIDER WALL	
Vertical 40/60	
Vertical 50/50	
Vertical 60/40	
Horizontal 40/60	
Horizontal 60/40	

	80 LITRE
HANDLES (NOT AVAILABLE ON MSTs)	
Side handle	■
WHEELS DIAMETER (HOLLOW OR SOLID AXLE)	
ø 200 mm	■
ø 250 mm	■
ø 300 mm	
ACCESSOIRES	
Lid opening via pedal	
Poste fixe	Standard
ANTI-ODOUR	
Anti-odour	■
LABELLING	
Photo injection on the lid	Standard
Sticker	■
Embossing insert on the lid	■
Hot foil stamping	■
IDENTIFICATION	
RFID Chip	■
Specific numbering	■

sulo.com

DATA-CITYBAC-80L-LA-EN-1-0-201221

SULO®